

< **Flame detector unit** >

ELECTRODE / UV-SENSOR FLAME DETECTION



SAITEK srl

www.saitek.it

info@saitek.it

Casalgrande (RE) ITALY Tel . +39 0522 848211 Fax +39 0522 849070







ATTENTION!

If assembly, adjustment, modification, use or maintenance they are not performed correctly, they can occur injury or damage.

Please read the instructions first to use the product to come installed according to regulations in force in the countries of installation.

Label example

		SAITEK srl Via IV Novembre 4 - 42013 CASALGRANDE (RE) ITALY	
mod. www.saitek.it			
ΔF1 -P001		LO 2023 10	
			
spec. According to EN 298			
V ~	230		
HZ	50/60		
W	15		
IP	40		
°C	0/+60		
Sens. 1,2 μA			
s/n ???????			
ATTENZIONE!!!! SCOLLEGARE L'ALIMENTAZIONE PRIMA DI APRIRE IL COPERCHIO		WARNING!!!! DISCONNECT POWER SUPPLY BEFORE OPEN THE COVER	

		SAITEK srl Via IV Novembre 4 - 42013 CASALGRANDE (RE) ITALY	
mod. www.saitek.it			
ΔF1q -P001		LO 2023 10	
			
spec. According to EN 298			
V ~	230		
HZ	50/60		
W	15		
IP	00		
°C	0/+60		
Sens. 1,2 μA			
s/n ???????			
ATTENZIONE!!!! SCOLLEGARE L'ALIMENTAZIONE PRIMA DI APRIRE IL COPERCHIO		WARNING!!!! DISCONNECT POWER SUPPLY BEFORE OPEN THE COVER	

ΔF1 Label encoding

ΔF1q - Pxxx

Customer Personalization
Equipment model

USE INSTRUCTIONS

Read carefully and preserve this use and maintenance reference manual.

ATTENTION!!!

Any indication and operation indicated in the present manual shall be carried out only by authorized and qualified personnel in charge.

Improper and incorrect assembly, adjustment, modification, use or maintenance can cause serious damages and accidents to persons and things.

Read carefully the instructions before installing the appliance. The assembly shall be in compliance with the regulations in force.

In order to prevent accidental electrocutions it is recommended you disconnect the electric current before opening the appliance.

Before supplying power check the value reported on the tag.

CONFORMITY

The manufacturer declares that:

- The **ΔF1 - ΔF1_q** has been designed, realized and tested in compliance with the European Rule **EN298** relative to "For flame detection and signalling in continuous operation with ionization control"
- The **ΔF1 - ΔF1_q** complies to the essential requirements provided for by following Directive:
 - 2006/42 in conjunction with the relevant sections of EN 746,
 - 2014/35/UE in conjunction with the relevant standards,
 - 2014/30/UE in conjunction with the relevant standards relating to radiation
- EMC emission requirements must be tested after incorporation into the equipment.

AF1-AF1q APPLICATIONS

ΔF1 - ΔF1_q provide to detection and indicate, when regularly employed, the presence of a flame.

The **ΔF1 - ΔF1_q** monitor intermittent flame, **or rather flame that shall be turned off at least once in the 24 hours.** The flame is checked by an ionization electrode or UV sensor.

For grounded or ungrounded mains.

The **ΔF1 - ΔF1_q** can be applied directly to the burner in industrial thermal processes for metals, glass, ceramic, plastic, chemical, etc....

Besides it can be applied on atmospheric burners for general heating.

ATTENTION

Avoid presence of condensation inside the box and on the card surface.

TECHNICAL SPECIFICATIONS

- Data relating to power supply characteristics (V ~ / Hz / W), working temperature (° C), IP00.
- **Flame detection with 1 electrodes or UV lamp**
- LED display: power on, flame detection OK and flame level.
- Alarm contact in exchange: energized when in flame detection.
- Operating voltage can be 230 V AC and 115 V AC (to be specified on order)

FLAME LEVEL VIEWER CARD

The **ΔF1 - ΔF1_q** flame control is supplied together with the additional display card STK035. This offers the opportunity to control the functionality of the equipment in a more effective and immediate way. This is made possible by the four LEDs for displaying the flame level.

ASSEMBLY

- Mounting position as desired

$\Delta F1$:

- Assembly of the fixed rear part, through 4 preformed holes to be removed by pressure.

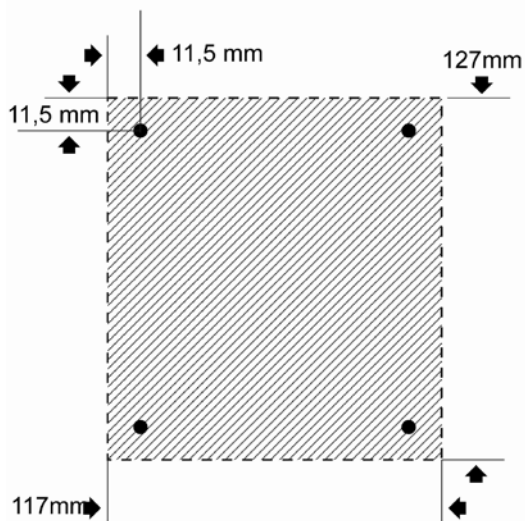

- Dimensions 117 x 127 x 122 mm
- Arranged for pipe fixing collar
- For the wiring there are 2 pre-fractures PG9 on the back.
- $\Delta F1$ can be supplied already wired, otherwise make the necessary holes only in the rear part and use cable glands that guarantee at least the same degree of IP protection declared

$\Delta F1_{\square}$:

Panel mount: rectangular hole and overall dimension.

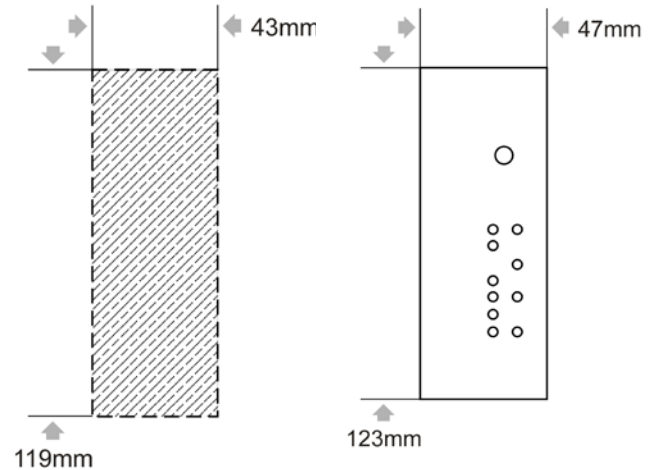

- Dimensions 47 x 123 x 105 mm

RECOMMENDED CABLES

IONIZATION: Maximum length 10 meters with recommended section not less 1 mm. Laying away from sources of disturbance, avoid external electrical influences.

WIRING

Remove power from the system.
 In three-phase systems, use the same phase on the inputs.

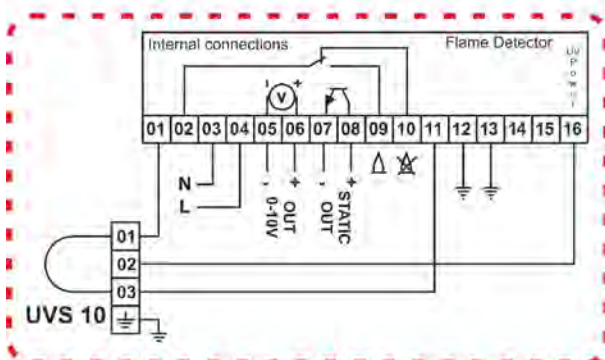
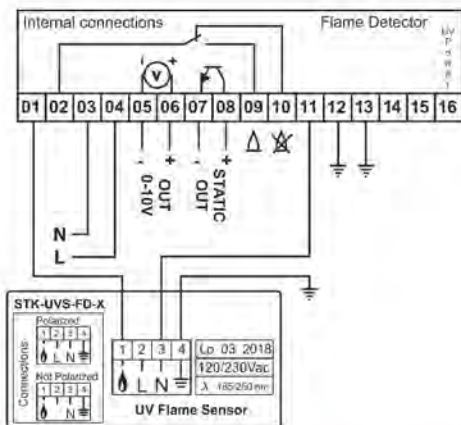
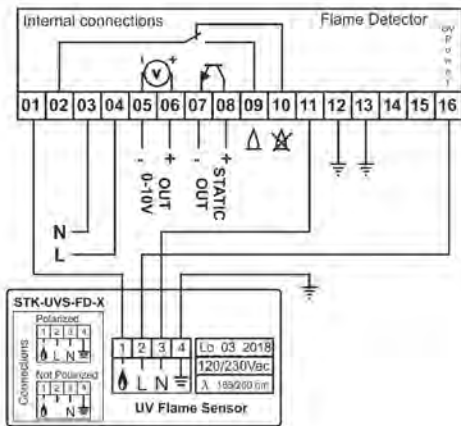
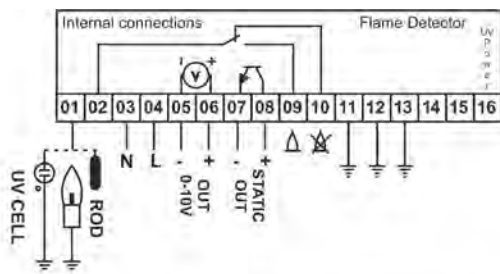

The presence of the flame can be detected by electrode or UV photocell. The use of UV Saitek photocells is recommended. UVS10 or others are however usually compatible.

$\Delta F1 - \Delta F1_{UV}$ must be employed only on industrial application.

An analog output is available to monitoring the flame detection level. **Warning:** this output is NOT galvanically isolated. Risk of electroshock, use only by qualified electricians. Output signal scale is from 0Vdc (0 uA) to 10Vdc (20uA) approximately.

A galvanically isolated open collector transistor output is available for fast signal response. Transistor closes when flame is detected. V_{max} 24Vdc. max 100mA with a 100 ohm resistor to limit the current that can cause it to break.

Output relay can support a maximum load of 1A 230Vac protect by internally fuse

CONNECTIONS

1. Flame Sensor INPUT (rod – UV cell)
2. Out contact - common
3. Neutral Power Supply
4. Line Power Supply(Declared on Label)
5. Negative 0-10V linear signal out
6. Positive 0-10V linear signal out
7. Negative static out
8. Positive static out
9. Out contact – Close flame present
10. Out contact – Close flame not present
11. PE Connection
12. PE Connection
13. PE Connection
14. Not connected
15. Not connected
16. UV sensor Power out

Make a good connection of the ground of AF1 to the body burner ground to ensure correct operation.

START SERVICE

1. Power to the $\Delta F1 - \Delta F1_{\square}$.
2. Start the system and light the burner in safety mode
3. If the flame is present, the flame detection led light on up and the led bar indicates the level of the signal flame. The relay switch and closes between terminals 2 and 9. The static output activates.
4. If the flame is not present, the detection LED and the LED bar remain off. The relay does not switch (it remains closed between terminals 2 and 10) and the static output remains deactivated.

OPERATION CHECK

1. Remove the detection connection during operation (TERMINAL 1) with an insulated tool.
2. $\Delta F1 - \Delta F1_{\square}$ Turns off the detection led and the detection bar. The relay closes between terminals 2 and 10. The static output deactivates.
3. If a different operation should occur check the wiring. This done if the problem has not been resolved disassemble the $\Delta F1 - \Delta F1_{\square}$ and send it to the manufacturer for a complete overhaul.

After replacing the safety device, check its operation by repeating the check.

Operation display

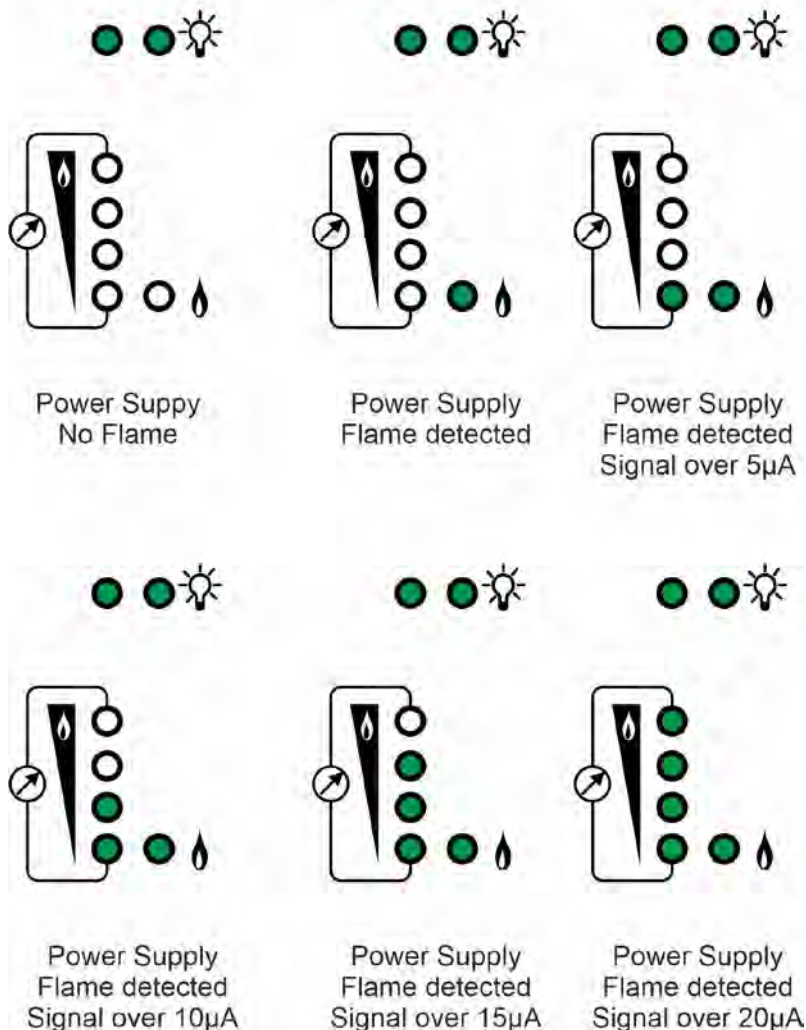

RETIFICATION OF FAULTS**CAUTION !!!**

Danger of death due to electric shocks!
Before intervening on the appliance cut
off the tension to any cable.

The elimination of breakdowns can be
carried out by authorized personnel
only.

In case of improper repairs or incorrect
electrical connections, the good
running of the appliance is not granted.

? < TROUBLE >
! < CAUSE >
* < REMEDY >

? THERE IS THE FLAME BUT THE
DETECTION LED IS OFF.

! The detection electrode is in short
circuit with burner body because of
dirt, soot or damp.

! The detection electrode is not in a
correct position as to the flame.

! The combustion air/gas ratio is
incorrect.

! The flame beam makes no contact
with the burner body because air
and/or gas pressure is too high.

! The burner or $\Delta F1 - \Delta F1_{\square}$ are not
earthed correctly by PE terminal
blocks connections.

! Short circuit with PE or detection
cable interruption.

! Phase and neutral connections
reversed.

! the UV photocell does not work

* Eliminate the defect.

? THE APPLIANCE GOES
IMMEDIATELY IN DETECTION.

! Anomaly on the detection (flame
simulation)

* Eliminate the cause of the flame
anomaly.

! Anomaly of the flame detection circuit.

* Send device to the manufacturer for
its control or replacement.

? THE EQUIPMENT DOES NOT
TURN ON

! There is no power

* check and restore power supply

! The internal fuse on power input is
broken

* change fuse

? DOES NOT CLOSE THE OUTPUT
CONTACT

! The internal fuse of contact is broken

* Check and eliminate the cause of the
break and replace the fuses

? THE APPLIANCE DOES NOT
START EVEN IF ALL THE
TROUBLES HAVE BEEN
ELIMINATED.

* Send device to the manufacturer for
its control or replacement.

WARRANTY

Saitek Co. Ltd warrants these appliances to be free from defects in material and workmanship for 12 months from the date of their installation up to a maximum of 18 months from the date of their original purchase by a consumer, provided that the appliances are properly used in accordance with their operating instructions and applications.

SAITEK srl

Via IV Novembre n° 4
42013 Casalgrande (RE) ITALY
<http://www.saitek.it> e-mail info@saitek.it
Tel. 0522.848211 fax 0522.849070